



ISRAEL
TALGIL COMPUTING & CONTROL LTD.
NAAMAN CENTER, HAIFA - ACCO ROAD 7000
P.O.BOX 775 KIRYAT MOTZKIN 26119, ISRAEL
TEL: 972-4-8775947; 972-4-8775948
FAX: 972-4-8775949
E-mail: talgil33@netvision.net.il

FILTRON

1-10 (DC/AC)

USER'S MANUAL

2011

FILTRON 1-10 (DC/AC)

List of features

- The “FILTRON 1-10” is a modular backflushing controller for automatic filters of 1 to 10 stations.
- There exist DC and AC models.
- The DC model can be powered either by 6v DC or 12v DC and it activates 2 wired 12v DC latching solenoids. The voltage for the solenoids switching is boosted by a charge pump.
- The AC model contains an internal transformer that can be powered by 110v or 220v from which it generates the 24v AC for the solenoids.
- Flushing cycles may be triggered either by time or by the embedded electronic DP sensor reaching the set point, or by a dry contact signal from an external DP sensor.
- Endless looping problems can be eliminated by detecting repeated consecutive cycles passing beyond a predefined limit.
- The unit can optionally handle a Pressure-Sustaining / Main valve, and an Alarm output.
- The unit is equipped with a customized LCD display and key board.
- The unit counts separately the number of flushing cycles triggered by DP, by time and manually.



How to program the controller

The controller is equipped with an LCD display and 4 keys as displayed below. When the unit is left untouched for a minute the display is switched off and the only life signal is given by a beep sound that can be heard every 20 seconds. Holding down any of the keys for a few seconds will bring the screen back to life.

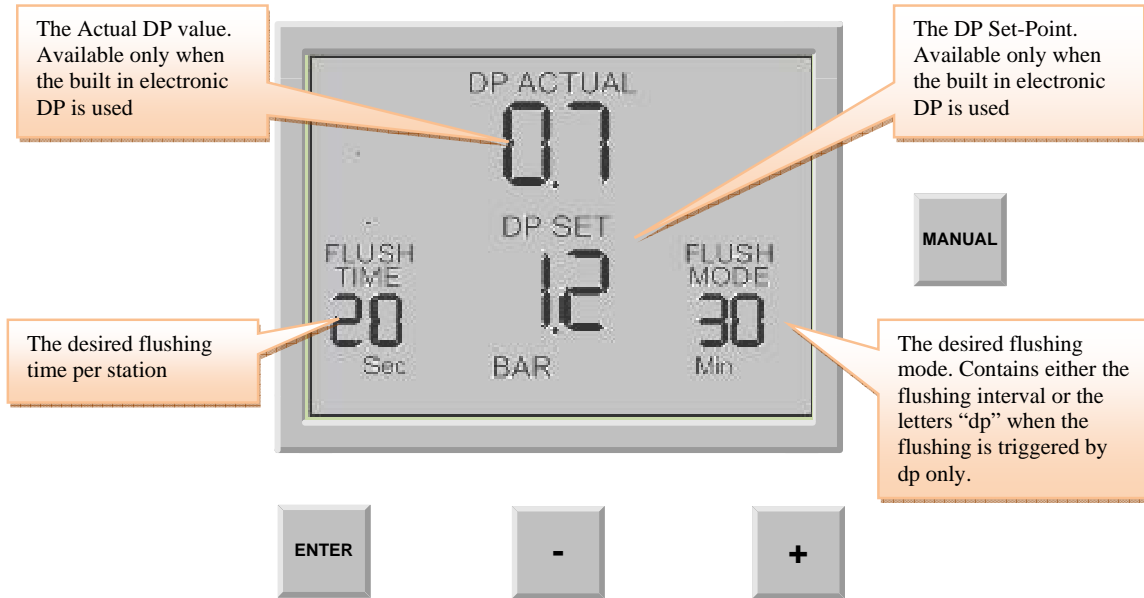

The screen consists of several fields, some of them are editable and some of them are not. For inserting EDIT MODE the ENTER key has to be pushed. The EDIT MODE is indicated by blinking of the characters at the currently editable field. Each time the ENTER key is pushed again, the next editable field becomes under focus and starts blinking. While in EDIT MODE the “+” and “-“ keys can be used for changing the value under focus. Pushing the ENTER key again will set the selected value to the current field and move the focus to the next editable field which will start blinking. Once entering this process of passing through the editable fields, the user has no way back but by pushing the ENTER key repeatedly, he passes through the chain of editable fields until arriving back to the FLUSH TIME field, meeting no more blinking fields.

REMARK Notice that before the first use of the unit, it may be necessary to pass through the configuration process prior to defining the flushing program in order to adjust the features of controller to the specific application. The configuration process is described below.

The chain of editable fields

Following is the chain of editable fields. The existence of the DP SET-POINT field depends on whether the system contains a built-in electronic DP or not.

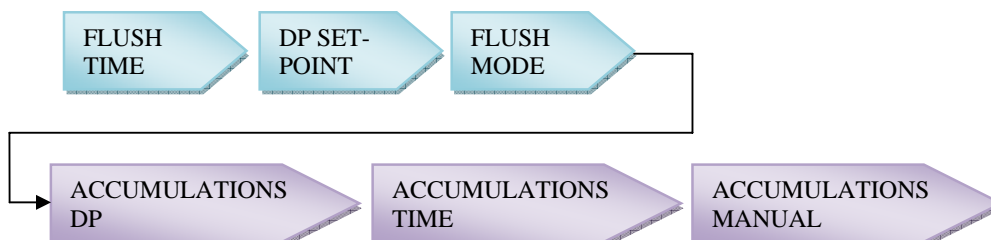

The Flush Time

Defines the duration of the flushing time per station. The following options are selectable:

5-20 sec in steps of 1 sec
20-55 sec in steps of 5 sec
1-6 min in steps of 0.5 min

The DP Set Point

At this field the user defines the pressure difference between the filter's inlet and outlet that when reached, a flushing cycle will take place. This field is meaningless when there is no built in electronic DP sensor included, therefore the user is expected to define the DP set point to be 00, as a result the actual DP value will appear as (- -).

When the pressure is expressed in BAR the range of values is 0.1 – 2.0 BAR.
When the pressure is expressed in PSI the range of values is 1- 30 PSI.

When the system does not include the built in electronic DP sensor but uses instead an external DP sensor, the flushing request signal arrives in the shape of a closed dry contact at the appropriate input terminals.

The Flush Mode

The Flush Mode defines how the flushing cycles is triggered. The selectable options are as follows:

OFF - no flushing will take place
By time – In this case the flushing cycles will be repeated in a selected interval or will be triggered by the DP signal depending on what happens first. No matter how was the flushing cycle started the interval to the next cycle will start to be measured again after each ending of a flushing sequence. The selectable intervals are the following:

5, 10, 15, 20, 25, 30, 35, 40, 45, 50, 55, 60 minutes
2, 3, 4, 5, 6, 8, 12, 18, 24, 72, 120 hours

dp – flushing will be triggered by DP only.



If the "+" and "-" keys are pressed and held down simultaneously the "Flush Mode" field will show the left time until next cycle, alternately hours and minutes.

The Accumulations

The unit accumulates and displays the number of flushing cycles caused by DP, by time, or manually. At each of the accumulation fields, the "+" or "-" keys may be used for clearing the accumulated value.

The Configuration

In order to enter into the configuration process press and hold down the ENTER key for at least 3 seconds.

The unit will detect how many “plug-in” boards (each of 2 outputs) are used in the particular case. How will the outputs be allocated depends on the definitions made during the configuration process described below. The following rules apply:

1. Backflush valves will be allocated starting from output 1 and up.
2. The last backflush valve can be canceled and then its allocated output will be left unused.
3. Alarm output, Delay-Valve and Main-Valve when defined, will be allocated in this order, right after the last backflush valve (whether in use or not).

Example:

Assuming there are 3 “plug-in” boards, this makes 6 outputs for use. If there are no Alarm-output, no Delay-Valve and no Main-Valve all the 6 outputs will be allocated for backflush valves. If additionally a Main-Valve is defined, the first 5 outputs will be allocated for backflush valves and output No 6 for the Main-Valve. Output No 5 (of the last backflush valve) can be canceled and left unused. If additionally a Delay-Valve is defined it will be allocated to output 5 right before the Main valve, leaving the first 4 outputs for backflush valves, and once again output No 4 (of the last backflush valve) can be canceled and left unused. If additionally an Alarm-output is defined it will be allocated before the Delay-Valve leaving only 3 of the first outputs for backflush valves. No 3 can again be canceled.

During the configuration process the following features are defined:

- Main Valve (sustaining valve) - Yes/ No. When the answer is “Yes” the Pre Dwell delay between the Main Valve opening and the opening of Station No. 1 can be defined. The selectable delay steps are:
5, 10, 15, 20, 25, 30, 35, 40, 45, 50, 55 sec
1, 1.5, 2, 2.5, 3, 3.5, 4, 4.5, 5, 5.5, 6 min
- Dwell time - the delay between stations – can be set to 5, 10, 15, 20, 25, 30, 35, 40, 45, 50, 55, or 60 sec.
- DP delay - the delay during which the DP sensor reading is expected to remain stable before reaction – 5, 10, 15, 20, 25, 30, 35, 40, 45, 50, 55, 60 sec.
- Looping limit - the number of consecutive flushing cycles triggered by the DP sensor before deciding that there is an endless looping problem. The options are: 1-10 or “no” which means ignoring the looping problem.
- Alarm - Yes/No – allocating one output for alarm activation.
- Delay Valve - Yes/No – allocating an output for Delay Valve activation.
- View Outputs - this is a special mode that enables passing through the list of outputs to see how each output was allocated. Use the + key to change the “no” into “yes” and confirm by “Enter”, then keep using the + key to pass through the list. At the bottom left corner the ordinal number of the output is displayed and its allocated function appears in large letters at the center of the screen. Notice that the number of possible outputs that can be used is always an even number since it results from the number of “plug in” boards (each of 2 outputs) included. However if the number of outputs needed is not an even number, then the last valve allocated for flushing may be canceled by use of the  manual operations key.
- Pressure units - deciding about the units to be used for pressure measurement. Selecting between BAR or PSI .
- Calibration- Zero calibration of the built in electronic DP sensor. While the sensor ports are disconnected select Calibration = Yes.

Handling Endless Looping problems

As explained above, endless looping problem will be declared when the number of consecutive flushing cycles triggered by the DP sensor exceeds the “Looping limit” defined during configuration. The fact that endless looping problem was detected will be indicated on the display and will cause the activation of the Alarm output, additionally, the DP indication will no longer be considered as a trigger for flushing. The following flushing cycles will be triggered by the interval count down only.

The problem will be considered as solved when the constant indication of the DP sensor will be removed.

Handling Low pressure

When a closed contact indication is received at the low pressure input of the controller, the symbol  will start to appear blinking at the display. All activities will stop including the countdown to the next flushing cycle. If the low pressure happened while a flushing sequence was in progress, when the low pressure condition terminates the flushing sequence will start from the beginning rather than continue from the stop point.

Connecting the DP sensor to the filter system

The DP sensor is connected to the filter system by 2 command tubes, the one which comes from the filter inlet (High pressure) will be connected to the red point, and the one that comes from the outlet (Lower pressure) will go to the black point. It is important to put a small filter of 120 mesh (not supplied) between the red point and the high pressure connection point.



The small filter to be added between the high pressure inlet and the red point. It is the user's responsibility to add this filter.

Low battery

The unit has two levels of low battery indication. At the first level when the battery voltage drops to the first level, the sign  will start to appear at the screen. When the battery voltage drops further and reaches the second level, all outputs will shut down, the screen will be cleared leaving only the low battery icon.

Manual activation

A flushing sequence can be manually activated by the “MANUAL” key. When manually activated the icon  will appear on the display. The same key will be used for manually terminating a sequence in progress.

Timing Diagram

Without Delay Valve

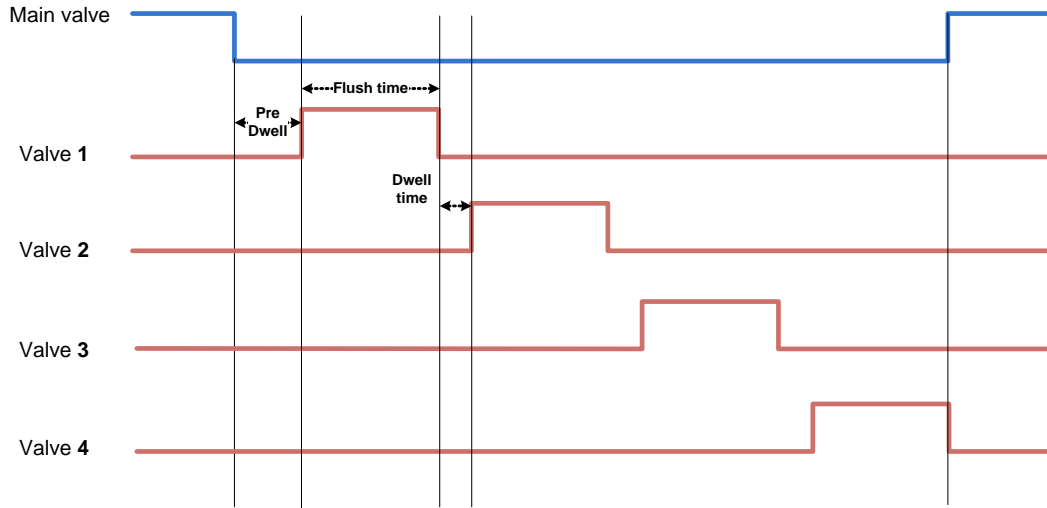

Including Delay Valve

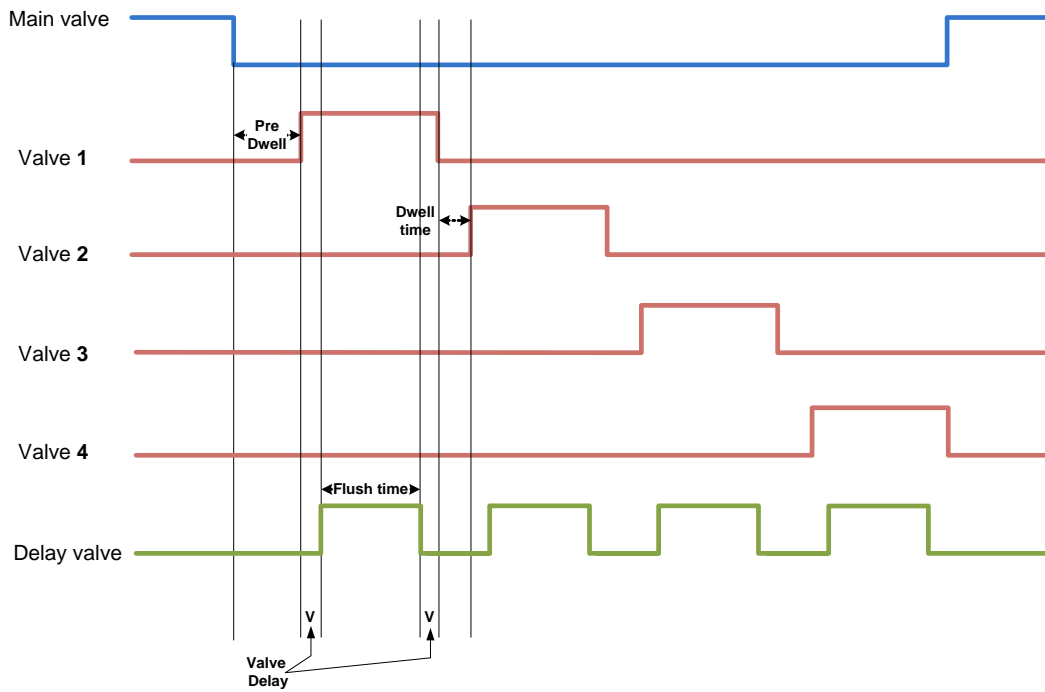

Wiring Diagram

DC MODEL

The drawing below shows the wiring of the DC model of the controller.

Notice that:

1. The External DP sensor is optional and it is intended for use in cases there is no Embedded Electronic DP included.
2. The powering of the unit can be either by 6v DC or 12v DC.
3. The solenoids will be of 12v DC latch.

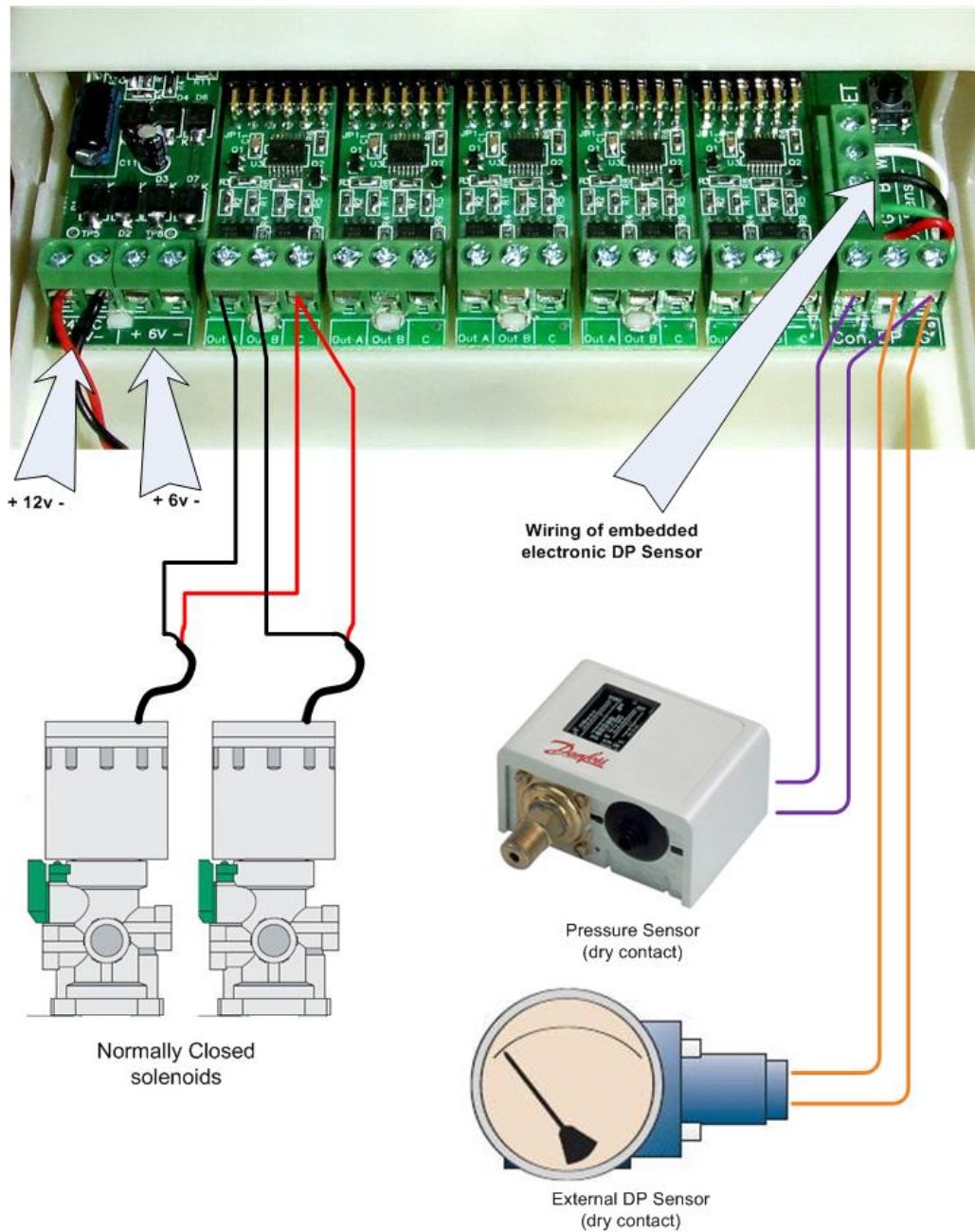

AC MODEL

The drawing below shows the wiring of the AC model of the controller.

Notice that:

1. The External DP sensor is optional and it is intended for use in cases there is no Embedded Electronic DP included.
2. The powering of the unit is by 24v AC transformed from 220/110 v AC.
3. The solenoids will be of 24v AC.

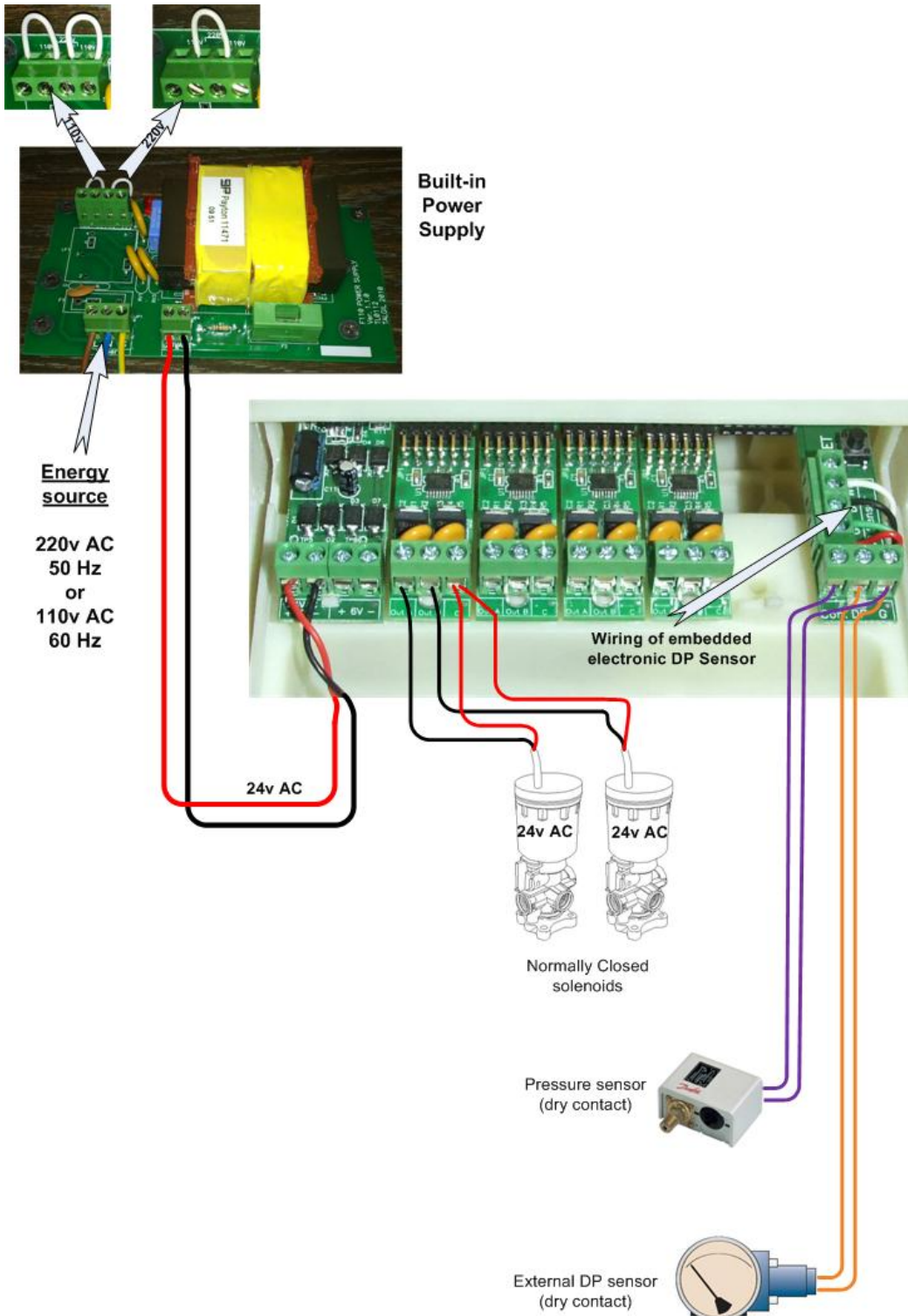

TECHNICAL DATA

DC MODEL

Power source:	6v supplied by 4 x 1.5 "D" size alkaline batteries. or 12v DC dry battery or 12v rechargeable battery with solar panel of 2 watts
Outputs :	12v DC latching solenoids.
DP:	Embedded electronic analog DP sensor or external dry contact DP sensor.
Pressure Sensor:	Dry contact pressure sensor
Operating temperature:	0-60° C.

AC MODEL

Power source:	220 or 110 v AC 50 or 60 Hz with built in transformer to 24v AC.
Outputs :	24v AC solenoids.
DP:	Embedded electronic analog DP sensor or external dry contact DP sensor.
Pressure Sensor:	Dry contact pressure sensor
Operating temperature:	0-60° C.